

RoHS SUS EN

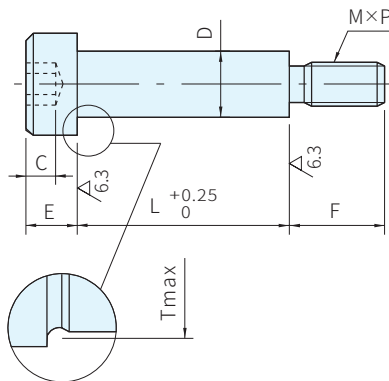
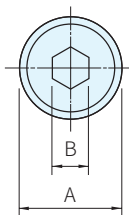
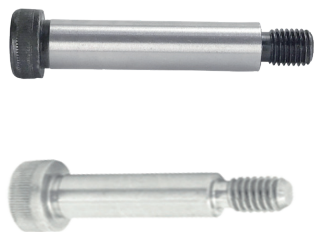

Type	材質	硬度	處理	級數
MSB	SCM435	HRC38~44	染黑	12.9
MSBS	SUS304	-	-	-

Df9		M×P	A	B	C	E	F	T
◎ 04	-0.010 -0.040	3×0.5	7	2	1.3	3.0	7	4.5
◎ 05		4×0.7	9	2.5	2.0	4.0	8	5.5
06	-0.013 -0.049	5×0.8	10	3	2.4	4.5	9.5	6.5
06.5		6×1	13	4	3.3	5.5	10	7.0
08		8×1.25	16	5	4.2	7.0	11	8.7
10		10×1.5	18	6	4.9	8.0	13	10.8
12		12×1.75	24	8	6.6	9.0	16	12.8
13	-0.016 -0.059							14.0
16		16×2	30	10	8.8	11.0	18	17.0
20		20×2.5	36	12	10.0	14.0	22	21.0
24	-0.020 -0.072							25.0

品號		L																						
TYPE	D	04	05	06	08	10	12	15	16	20	25	30	35	40	45	50	55	60	65	70	75	80	85	
MSB (鋼)	◎ 04	.*	.*	.*	.*	.*	.*		.*	.*	.*	.*												
	◎ 05		.*	.*	.*	.*	.*		.*	.*	.*	.*		.*										
	06					.*	.*		.*	.*	.*	.*		.*	.*	.*	.*	.*	.*	.*	.*	.*	.*	.*
	06.5					.*	.*		.*	.*	.*	.*		.*	.*	.*	.*	.*	.*	.*	.*	.*	.*	.*
	08					.*	.*		.*	.*	.*	.*		.*	.*	.*	.*	.*	.*	.*	.*	.*	.*	.*
MSBS (不銹鋼)	10					.*	.*		.*	.*	.*	.*		.*	.*	.*	.*	.*	.*	.*	.*	.*	.*	.*
	12					.*	.*		.*	.*	.*	.*		.*	.*	.*	.*	.*	.*	.*	.*	.*	.*	.*
	13					.*	.*		.*	.*	.*	.*		.*	.*	.*	.*	.*	.*	.*	.*	.*	.*	.*
	16					.*	.*		.*	.*	.*	.*		.*	.*	.*	.*	.*	.*	.*	.*	.*	.*	.*
	20					.*	.*		.*	.*	.*	.*		.*	.*	.*	.*	.*	.*	.*	.*	.*	.*	.*
24					.*	.*		.*	.*	.*	.*		.*	.*	.*	.*	.*	.*	.*	.*	.*	.*	.*	

品號		L											
TYPE	D	90	95	100	110	120	130	140	150	160	180	200	
MSB (鋼)	◎ 04												
	◎ 05												
	06	.*		.*									
	06.5			.*									
	08	.*		.*									
MSBS (不銹鋼)	10	.*	.*	.*	.*	.*	.*	.*	.*	.*	.*	.*	
	12	.*	.*	.*	.*	.*	.*	.*	.*	.*	.*	.*	
	13	.*	.*	.*	.*	.*	.*	.*	.*	.*	.*	.*	
	16	.*	.*	.*	.*	.*	.*	.*	.*	.*	.*	.*	
	20	.*	.*	.*	.*	.*	.*	.*	.*	.*	.*	.*	
24	.*	.*	.*	.*	.*	.*	.*	.*	.*	.*	.*		

訂貨： 品號 - L 交期： 1 天 MSB
MSB06 - 10 15 天 MSBS

備註

- *符號表示MSBS規格
- ◎符號表示非ISO 7379規範

PS 備註

- MSB調整長度用華司請參考華司·墊片單元MSRBB·PW
- 特殊長度和JIS規格，歡迎洽詢

EX 使用例

